

Company ↘

SECIL's highly automated factory in Turkey and Belarus produce thousands of different seals every year, with a high level of quality management for different sectors. We have know-how regarding rubber mixing, moulding, machinery, rubber extrusion, and injection. Experience on different production processes like covered seals, mono, co-ex, tri-ex, with cord, metal insert or many others.

↘ Quality & Performance

SECIL quality controls from incoming raw materials to finished products are made by specialists independent of the production process of Secil. Tests are also made by third part controlling company upon demand. This double quality control guarantees a constant quality of all SECIL products.

Secil Vertical Load Distributor

for Concrete Manholes

CERTIFICATIONS

SECİL KAUÇUK extensively involved with standardization committees and collaboration with leading testing institutes and authorities around the world. SECİL KAUÇUK is also a customer-driven company. If customers require certificates that demonstrate compliance with various standards SECİL KAUÇUK will apply for the certification process at the competent institutions.



Example of authorities Seçil Kauçuk cooperating with



FACTORY / HEAD OFFICE
Tarsus Adana Karayolu 7. Km. 33400 Tarsus-Mersin /TURKEY
Phone: +90 324 616 11 40 Fax: +90 324 616 04 04
Web: www.seciltr.com E-Mail: seciltr@seciltr.com





SECIL Vertical Load Distributor (VLD) is coextruded and “non-springy” solution in order to prevent concrete to concrete contact. SECIL pipe seals and fittings for underground drainage and sewerage are based on engineered solutions, fast design and prototyping on broad experience.

Material

- EPDM rubber mixing is our main strength.
- NON-SPRINGY core of the seal.
- In all cases, we use compound from our own mixing facilities.
- Further development and approval process ongoing.
- EPDM is the most popular material protected against ozone and high chemical resistance.
- EPDM can be expected to outlast the pipes lifetime.

Packing & Marking

- Different packing possibilities prepared on our customer needs.
- Secil products are marked with dimensions and the date of manufacture.
- The box is labelled with the corresponding data.

Sample Assembly

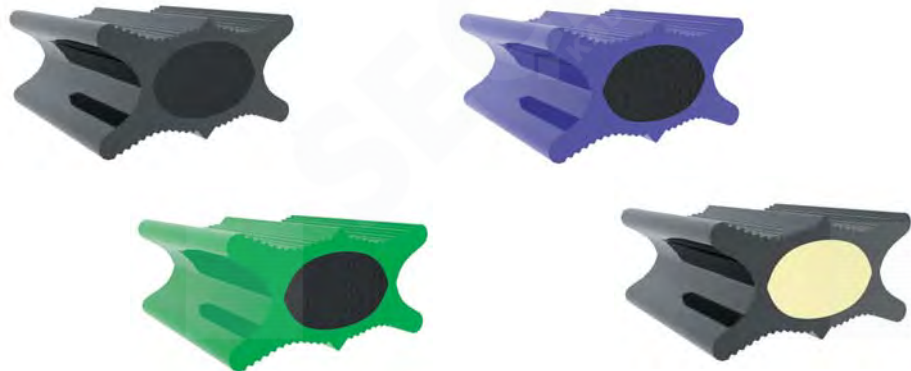
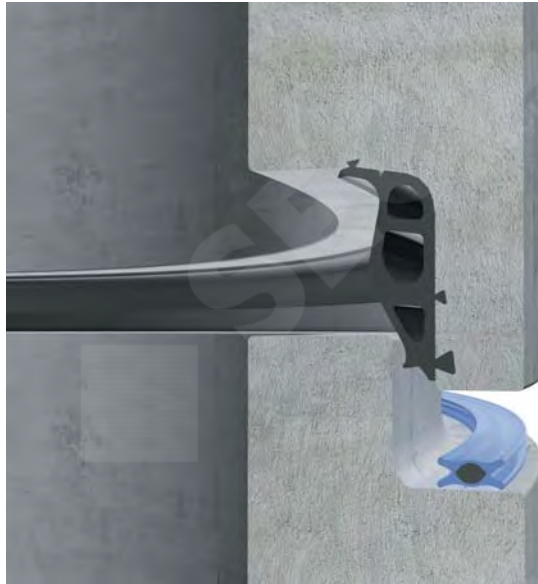

VLD Design

Secil work closely together with pipe and machine manufacturers with regard to design of correct pipe seals. We can also provide technical support to our customers with sales support in different languages in a range of different countries.

Example of Dimensions

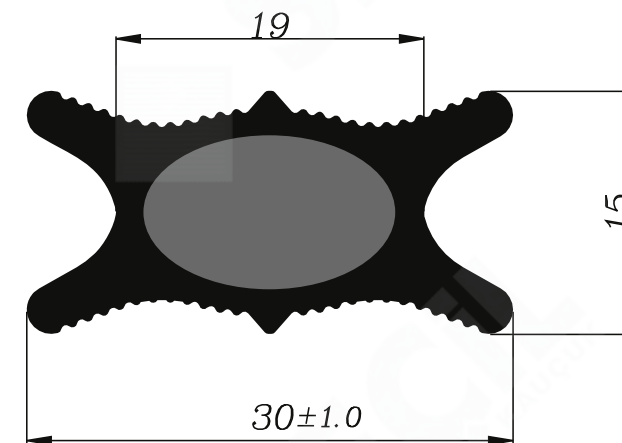

* Values and properties shown in diagrams and tables are not subject to any guarantees. Our warranty is limited to the values and properties as required by the relevant standards.
* Our literature, data sheets and recommendations represent our knowledge at the time of printing but are in no way legally binding on us. Our “General Conditions of Sale” apply to all sales.

